



Features

- ROHS Compliant
- High power rating
- High rejection

Pricing

Quantity	Unit Price
1 ~ 10	₩ 30,000
11 ~ 24	₩ 28,000
25 ~ 49	₩ 25,000
50 ~ 99	₩ 21,000
100 ~	₩ 16,000

Electrical Specifications

Parameter	Frequency (MHz)	Min.	Typ.	Max.	Unit
Center frequency	117	-	117	-	MHz
Bandwidth	1.8	116.1	-	117.9	MHz
Insertion Loss	116.1 ~ 117.9	-	3.0	3.5	dB
Ripple		-	0.3	0.5	dB
Return Loss		16.0	18.0	-	dB
Group Delay		-	-	-	ns
Group Delay Variation		-	-	-	ns
Attenuation		124.8	20.0	-	-
	-	-	-	-	dB
	-	-	-	-	dB
	-	-	-	-	dB
	-	-	-	-	dB

Maximum Ratings

Input Power Handling	3Watt max.
Operating Temperature	-30°C to 70°C
Storage Temperature	-40°C to 95°C

• Permanent damage may occur if any of these limits are exceeded.

Dimension

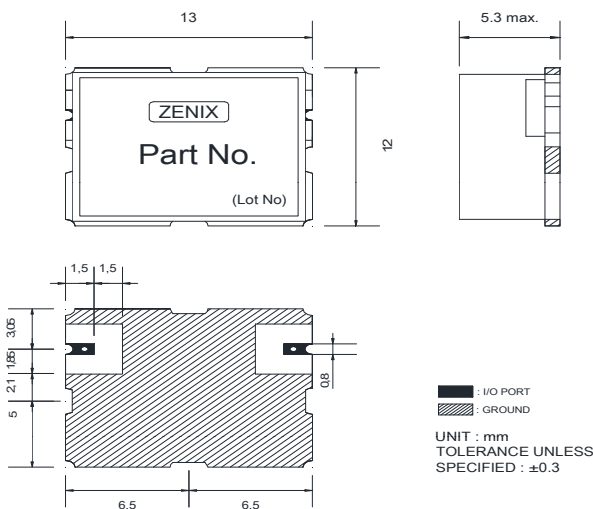

PCB Layout

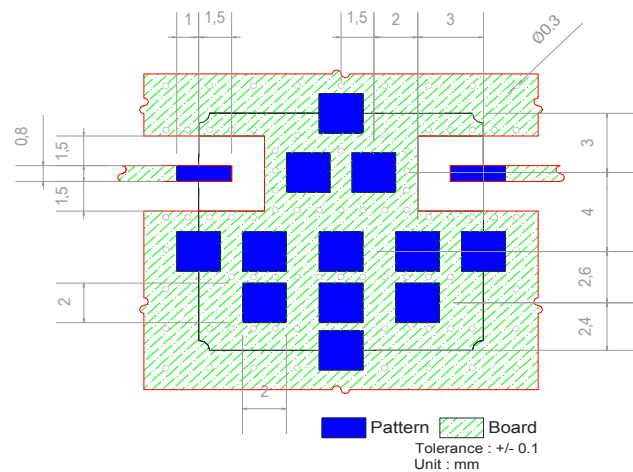

Typical Performance Data at 25°C

- Insertion Loss, Ripple, Return Loss, Attenuation

